



A Cavagna Group Brand

S26 Slam Shut Valve Product Bulletin





A Cavagna Group Brand

1 PRODUCT OVERVIEW

The S26-VDB, commonly referred to as the S26, is a slam shut safety device that can provide Over Pressure Shut Off (OPSO) and/or Under Pressure Shut Off (UPS0). The S26 is the same slam shut technology used on the Mesura S22 and S23 regulators. Featuring full open orifice designs, the S26 is designed to minimize pressure drop and provide simple, reliable operation. S26 slam shut valves offer dependable over pressure protection with complete installation flexibility.

The S26-VDB is designed and tested to the EN14382 standard for Gas safety shut-off devices.

2 MATERIALS OF CONSTRUCTION

MOUNTING FLANGE: Brass Alloy

SSV SUPPORT: Aluminum Bar Stock

COVER: Aluminum

SPRINGS: Stainless steel

STEM: Stainless steel

ADJUSTING SCREW: Brass

BALL BEARING: Stainless steel

FITTINGS: Steel

DISCS AND O-RINGS: Nitrile (NBR)

DIAPHRAGMS: Nitrile/Reinforced (NBR)

DIAPHRAGM PLATES: Steel

CLOSING CAP: Brass

FASTENERS: Steel

PRESSURE SENSING: External

3 SPECIFICATIONS

Table 1: S26-VDB Specifications

Table 1: S26-VDB Specifications						
Max Operating Inlet Pressure	BP&MP	87 psig	6 bar	Emergency Inlet Pressure	290 psig	20 bar
	APTR	290 psig	20 bar	Emergency Outlet Pressure (Casing)	87 psig	6 bar
Operating Outlet Pressure Range		See Table 2		Operating Temperature	-20 to 70 °C -4 to 160 °F	
Maximum Outlet Pressure to avoid damage to internal parts	BP	5 psig	0.345 bar	Over Pressure Shut Off Accuracy	BP: AG 10 MP & APTR: AG 5	
	MP	15 psig	1.03 bar			
	APTR	87 psig	6 bar	Under Pressure Shut Off Accuracy	BP: AG 20 MP: AG 10 APTR: AG 5	
Vent Connection	1/8" NPT					
Sense Line Connection	1/8" NPT or 1/4" NPT					

BP: Base Pressure, MP: Medium Pressure, APTR: Apex Pressure Travel Restricted

4 SPRING SPECIFICATIONS

Additional spring ranges are available.

Table 2: S26 OPSO Spring Ranges				
Model	Part Number	Color	Pressure Range	
			PSIG	mbar
BP	32-R-190-0015	Stainless Steel	8 - 16" WC	20 - 40
	32-R-190-0195	Red	16 - 28" WC	40 - 70
	32-R-190-0196	Green	28.1 - 56" WC	70 - 140
	32-R-190-0101	Blue	44.2 - 84" WC	110 - 210
MP	32-R-190-0023	White	3.7 - 6.1	250 - 420
	32-R-190-0020	Orange	4.8 - 6.5	330 - 450
	32-R-190-0024	Brown	6.25 - 8.0	430 - 550
	32-R-190-0016	Light Blue	8.0 - 13.0	550 - 895
APTR	32-R-190-0101	Blue	4.35 - 6.6	300 - 455
	32-R-190-0023	White	10.2 - 13.0	700 - 900
	32-R-190-0020	Orange	13.1 - 16.6	900 - 1150
	32-R-190-0024	Brown	16.25 - 24.4	1120 - 1550
	32-R-190-0016	Light Blue	21 - 32.6	1450 - 2250
	32-R-190-0017	Sard Grey	29.75 - 40.6	2050 - 2800
	32-R-190-0112	Pink	36.3 - 48.5	2500 - 3350
	32-R-190-0102	Violet	43.6 - 65.2	3000 - 4500
	32-R-190-0197	Black	65.3 - 75.4	4500 - 5200

Table 3: S26 UPSO Spring Ranges				
Model	Part Number	Color	Pressure Range	
			PSIG	mbar
BP	32-R-190-0198	Stainless Steel	3.2 - 6" WC	8 - 15
	32-R-190-0025	Red	6 - 20" WC	15 - 50
	32-R-190-0026	Green	18 - 40" WC	45 - 100
MP	32-R-190-0021	Blue	1.45 - 3.6	100 - 250
	32-R-190-0199	White	3.33 - 6.8	230 - 470
APRT	32-R-190-0200	Brown	1.45 - 3.6	100 - 250
	32-R-190-0021	Blue	2.9 - 7.25	200 - 500
	32-R-190-0199	White	5.8 - 13	400 - 900
	32-R-190-0018	Orange	8.7 - 36.25	600 - 2500
	32-R-190-0201	Light Blue	29 - 43.5	2000 - 3000

5 PRINCIPAL OF OPERATIONS

S26-VDB75/150/600 (NPS 1-2) Construction:

The device is held in the open position by a system of ball bearings that, when positioned as shown in Figure 1, holds the plug in the open position. When the sensed pressure increases or decreases, the movement of the diaphragm (D) releases the ball bearings which allows the plug (P), under the action of the spring (K) to stop the flow of gas by sealing against the seat (S).

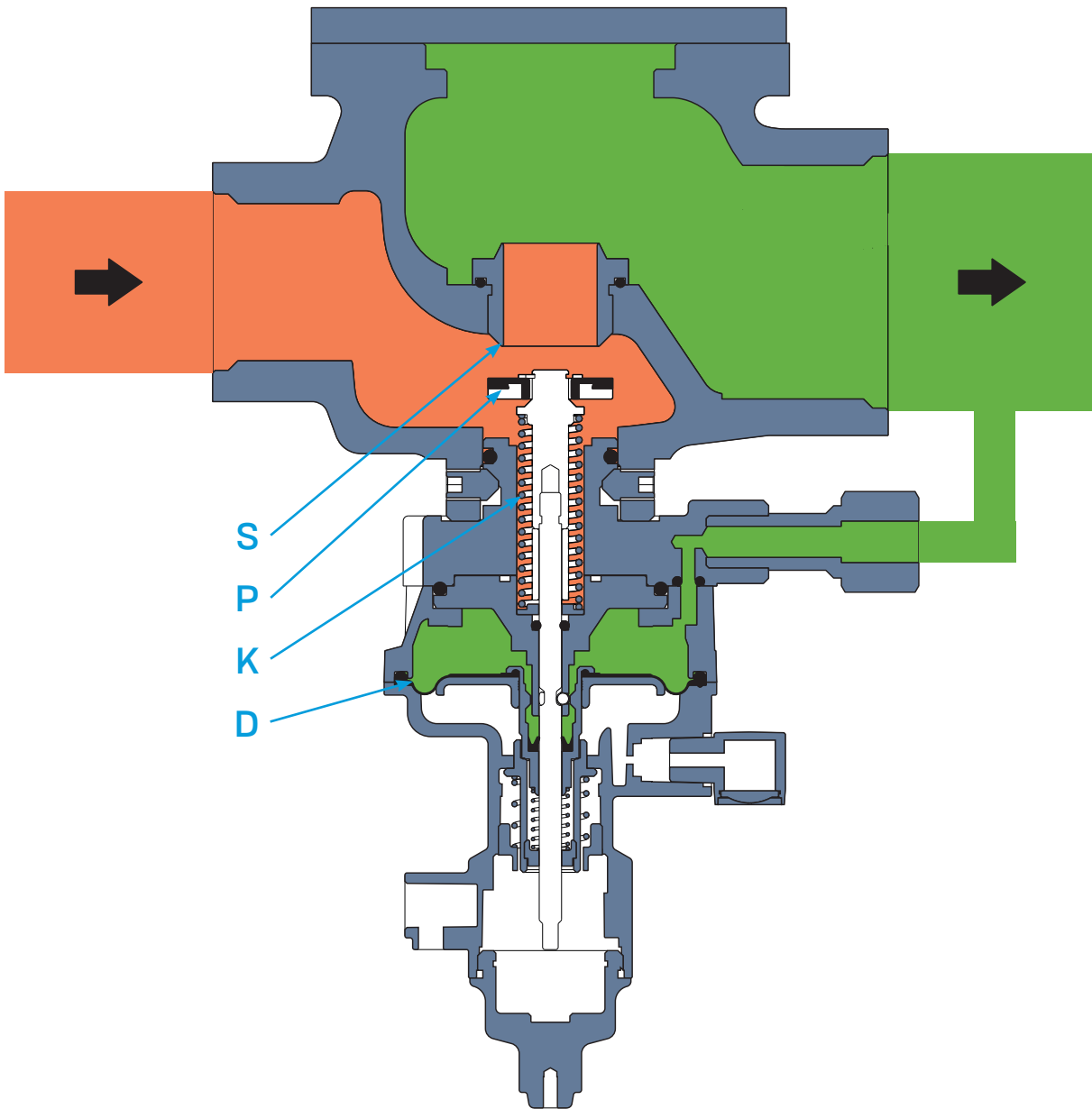

Figure 1: S26-VDB75/150/600 Schematics

S26-VDB80 (NPS 3) Construction:

The sensing module for the 3" construction operates the same as the 2" model. However when the ball bearings release the stem, they also allow the secondary stem (N) to rotate allowing the internal spring (K) to release and close the plug (P) against the seat (S). Stopping the flow of gas.

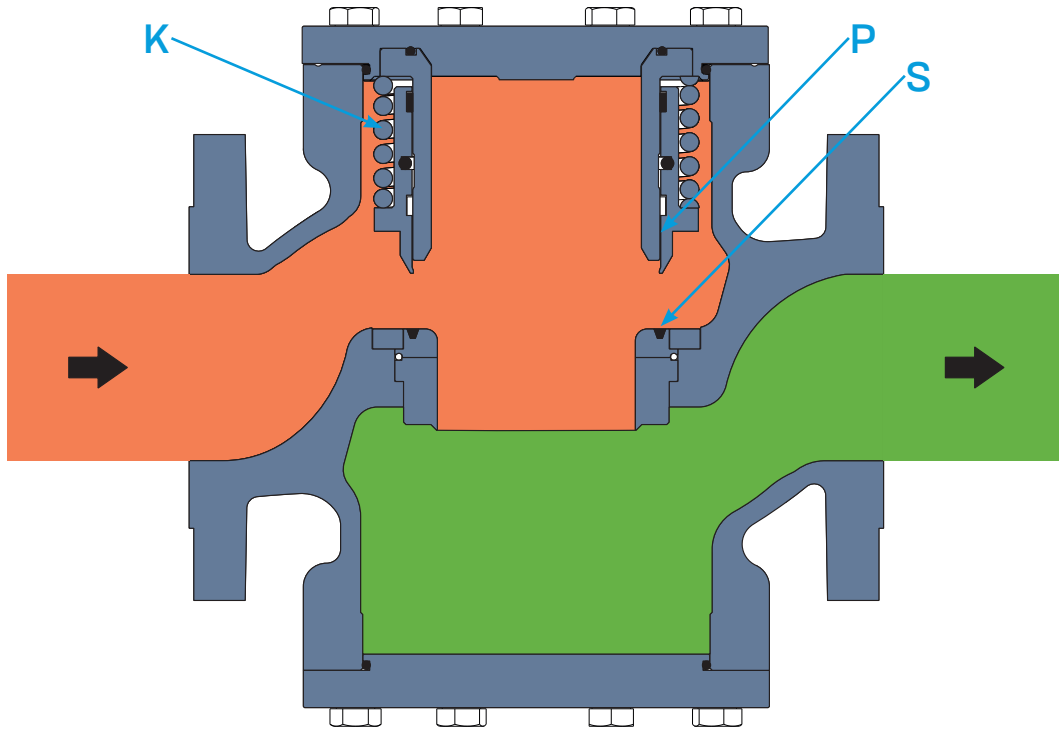

Figure 2: S26-VDB80 Body View

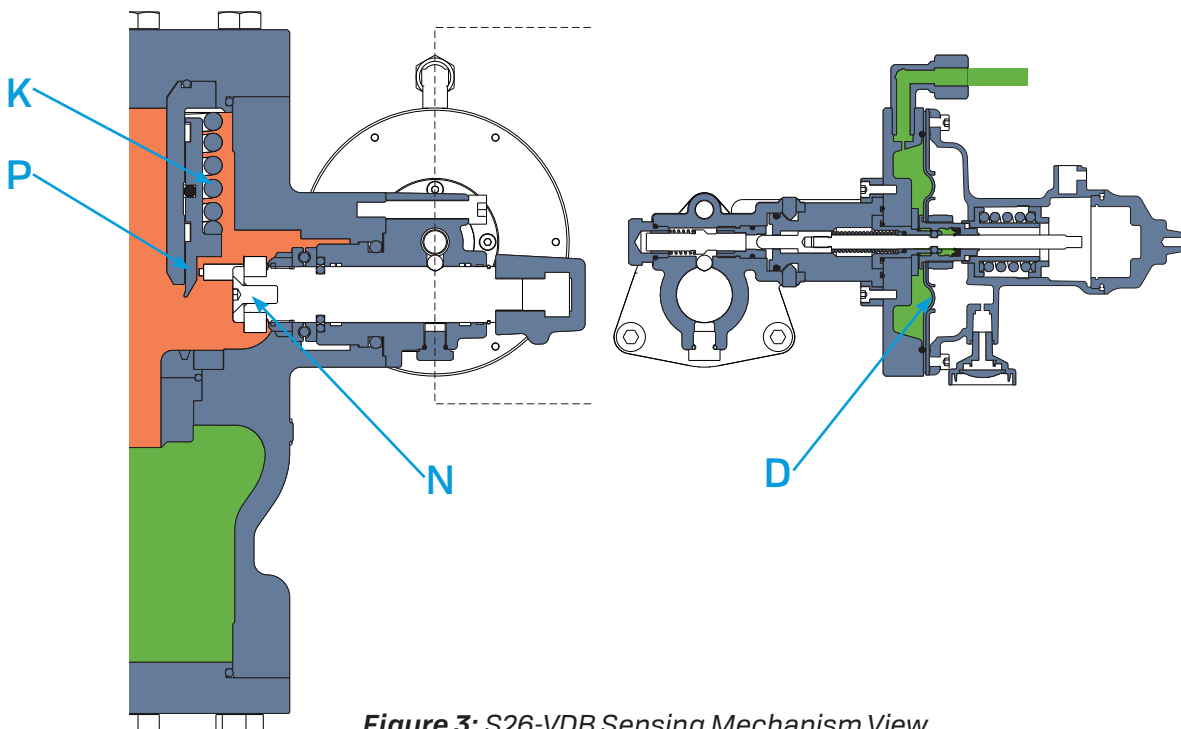

Figure 3: S26-VDB Sensing Mechanism View

6 CAPACITY INFORMATION

The selection of the SSV is determined by Flow Coefficient (K_g) calculation and allowable pressure drop. The K_g value was measured and calculated according to EN334. Pressure loss across the SSV will vary with flow rate. It is recommended to size for the largest flow rate at the lowest system inlet pressure.

Table 4: Sizing Coefficients			
Size	VDB	Cv Value	Orifice Size
1"	75	6.3	0.70"
1 x 1.5"	150		
2"	600	23	1.375"
3"	80	95	3.35"

The formulas below are provided by EN14382 and have been simplified for standard units. Use the Cv values provided above to calculate the flow or pressure drop for your application. Note that it is always recommended to use the data in Figures 4-7 as these equations are based on that same data.

The pressure loss (pressure drop) can be calculated using the formula below from EN 14382 C.1:

$$\Delta P_{bar d} = \frac{1}{163,747} \times \frac{t_u + 273.15}{P_u} \times \frac{Q_n^2}{C_v^2} \times d$$

Where:

- Q_n = Flowrate in Sm³/hour of 0.6 SG Natural Gas
- C_v = Valve Flow Coefficient from Table 2
- P_u = Inlet pressure in absolute bar (BARA)
- t_u = Gas temperature at the inlet of the SSD in °C
- d = Gas relative density to air

For ease of use, the below simplified formulas are provided for users. These formulas assume a gas temperature (t_u) of 60 °F and a gas density (d) of 0.6 relative to air. These formulas have been modified for imperial units.

Use the formula below to calculate the pressure drop in PSID:

$$\Delta P_{PSID} = \frac{Q^2}{C_v^2 \times P_{1,ABS} \times 5,600}$$

Where:

- Q = Flowrate in SCFH of 0.6 SG Natural Gas
- C_v = Valve Flow Coefficient from Table 2
- P_{1,ABS} = Inlet pressure in absolute psi (PSIA)

To calculate the maximum flow in SCFH at a given pressure drop, use the formula below:

$$Q_{SCFH} = C_v \sqrt{\Delta P \times P_{1,ABS}}$$

Where:

- Q_{SCFH} = Flowrate in SCFH of 0.6 SG Natural Gas
- C_v = Valve Flow Coefficient from Table 2
- P_{1,ABS} = Inlet pressure in absolute psi (PSIA)
- ΔP = Pressure Drop, P₁ - P₂ (PSID)

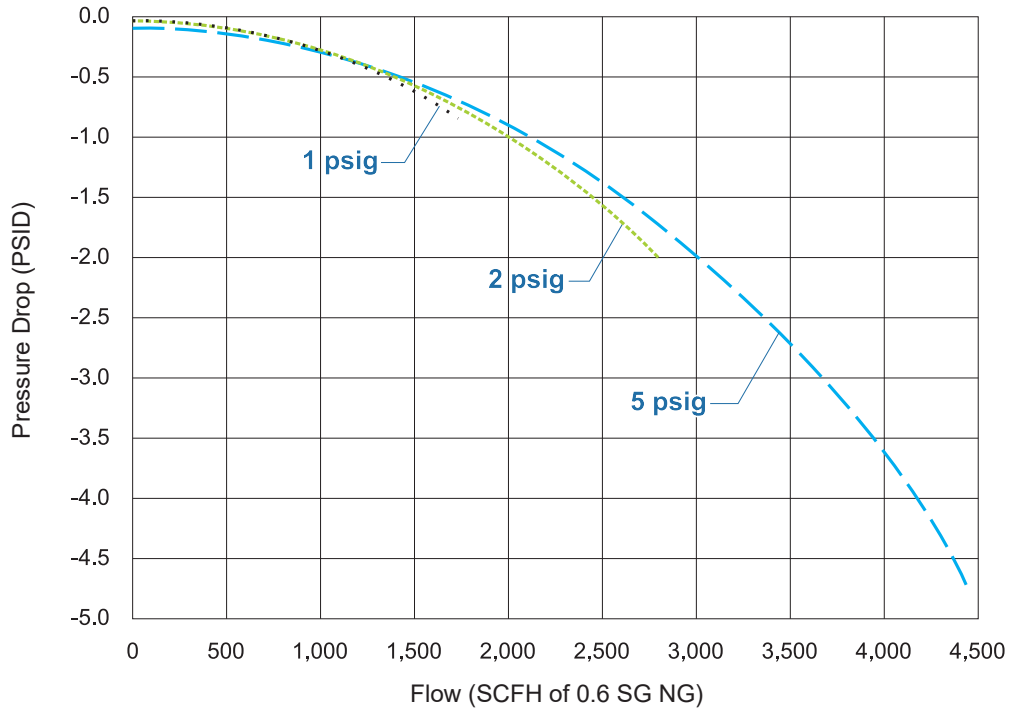

Figure 4: 1" S26-VDB75 Flow vs. Pressure Drop Data

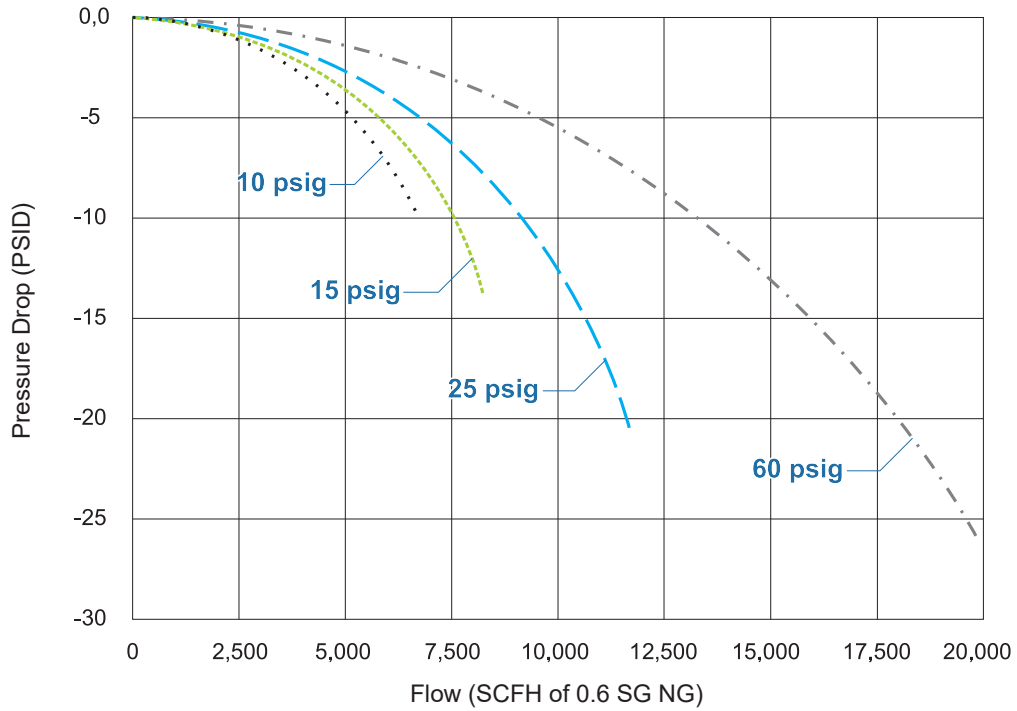

Figure 5: 1" S26-VDB75 Flow vs. Pressure Drop Data



A Cavagna Group Brand

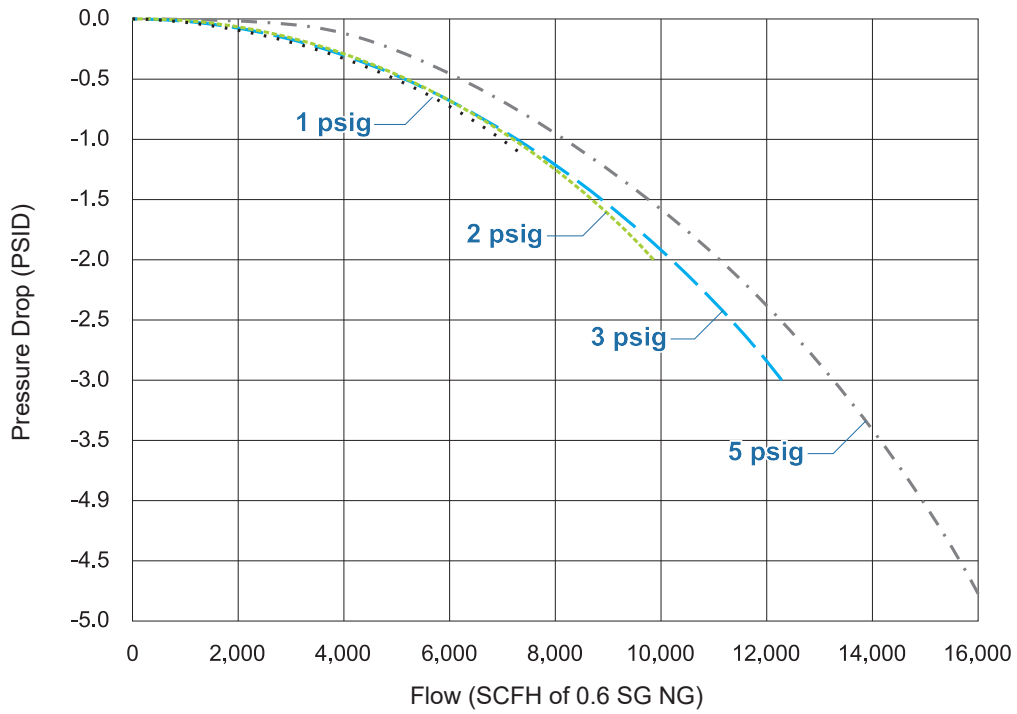

Figure 6: 2" S26 - VDB600 Flow vs. Pressure Drop Data

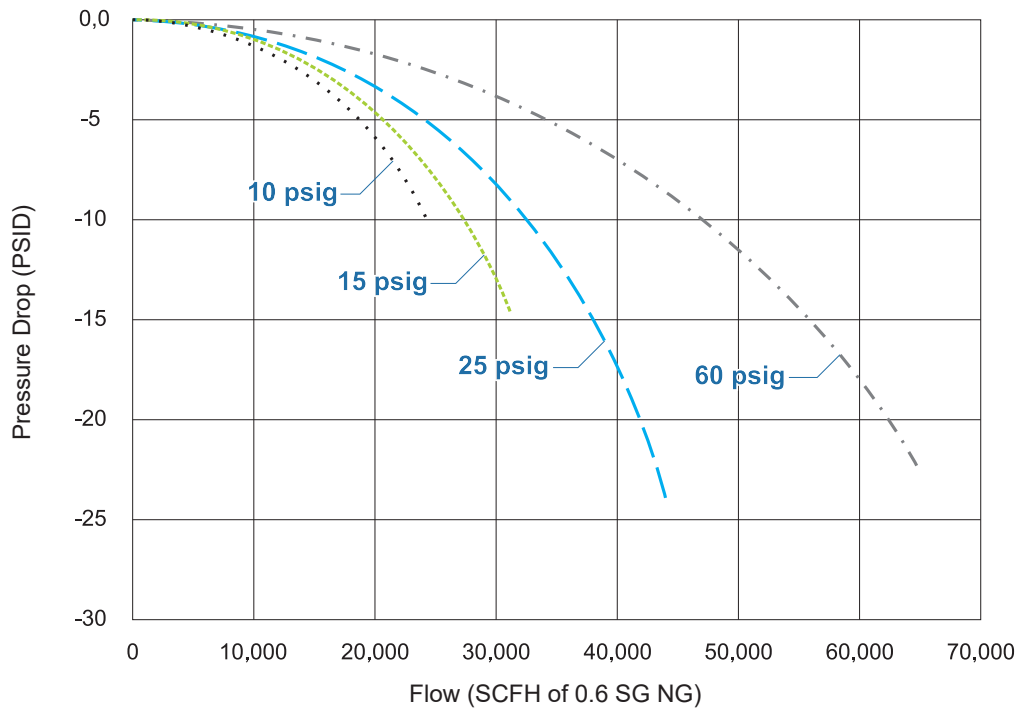

Figure 7: 2" S26 - VDB600 Flow vs. Pressure Drop Data

7 PRODUCT MARKING & IDENTIFICATION

The S26 slam shut valves used in pressurized systems will be identified with nameplates like the example below:



 		Via Matteotti, 5 25012 CALVISANO (BS) MADE IN ITALY		 1370	
S26-VDB### ####/###			S/N: XXXXXXX		
OPSO Set Point	XXX PSIG	OPSO Range	XXX - XXX PSIG		
UPSO Set Point	XXX PSIG	UPSO Range	XXX - XXX PSIG		
Max Inlet	XXX PSIG	Max Sensed Pressure	XXX PSIG		
Operating Temp.	XXX Deg	Emergency Casing:	XXX PSIG		
Functional Class	A	EN 14382	DOM: MM/YY		

Figure 8: S26 Nameplate

The S26-VDB contains a simple numbering system in the top left corner of the nameplate to help identify the exact construction. This product code can also be used for inventory and ordering. See table below for details:

Table 5: S26 Product Coding						
S26-VDB	Body/ Orifice	-	OPSO Spring	/	Upso Spring	Description
	75					1x1" NPT Body 0.7"
	150					1x1.5" NPT Body 0.7"
	600					2" CL125 or CL150 Body 1.375"
	50					2" CL125 or CL150 Body 2"
	80					3" CL150 Body 3.35"
	XX		NO OPSO		-	
	11		SST		8 - 16" wc	BP: Base Pressure
	12		Red		16 - 28" wc	
	13		Green		28.1 - 56" wc	
	14		Blue		44.2 - 84" wc	
	21		White		3.7 - 6.1	MP: Medium Pressure
	22		Orange		4.8 - 6.5	
	23		Brown		6.25 - 8.0	
	24		Light Blue		8.0 - 13.0	
	31		Blue		4.35 - 6.6	APTR: Apex Pressure Travel Restricted
	32		White		10.2 - 13.0	
	33		Orange		13.1 - 16.6	
	34		Brown		16.25 - 24.4	
	35		Light Blue		21 - 32.6	
	36		Dark Grey		29.75 - 40.6	
	37		Pink		36.3 - 48.5	
	38		Violet		43.6 - 65.2	
	39		Black		65.3 - 75.4	
	XX		NO UPSO			
	11		SST		3.2 - 6" wc	BP: Base Pressure
	12		Red		6 - 20" wc	
	13		Green		18 - 40" wc	
	21		Blue		1.45 - 3.6	MP: Medium Pressure
	22		White		3.33 - 6.8	
	31		Brown		1.45 - 3.6	APTR: Apex Pressure Travel Restricted
	32		Blue		2.9 - 7.25	
	33		White		5.8 - 13.0	
	34		Orange		8.7 - 36.25	
	35		Light Blue		29 - 43.5	



A Cavagna Group Brand

8 CONFIGURATIONS & DIMENSIONS

1 - 1.5"
Threaded
Bodies

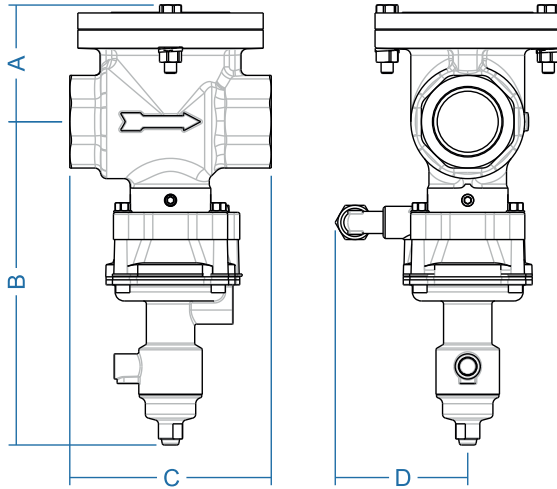

2" CL125 & CL150
Flanged
Bodies

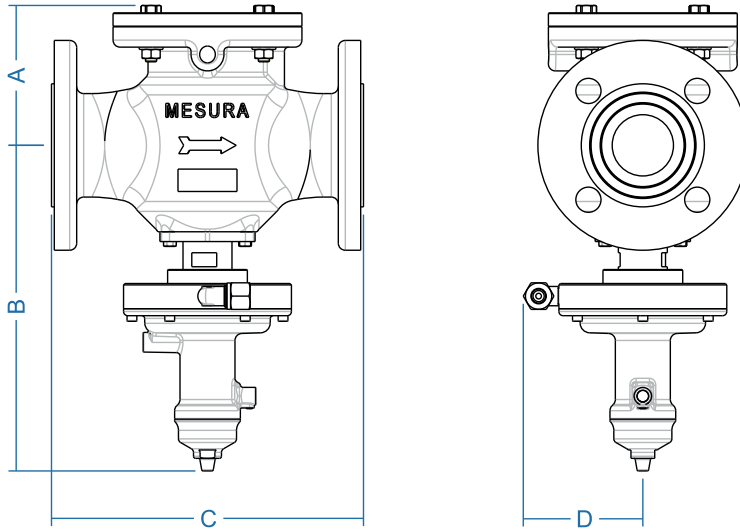

3" CL150
Flanged
Bodies

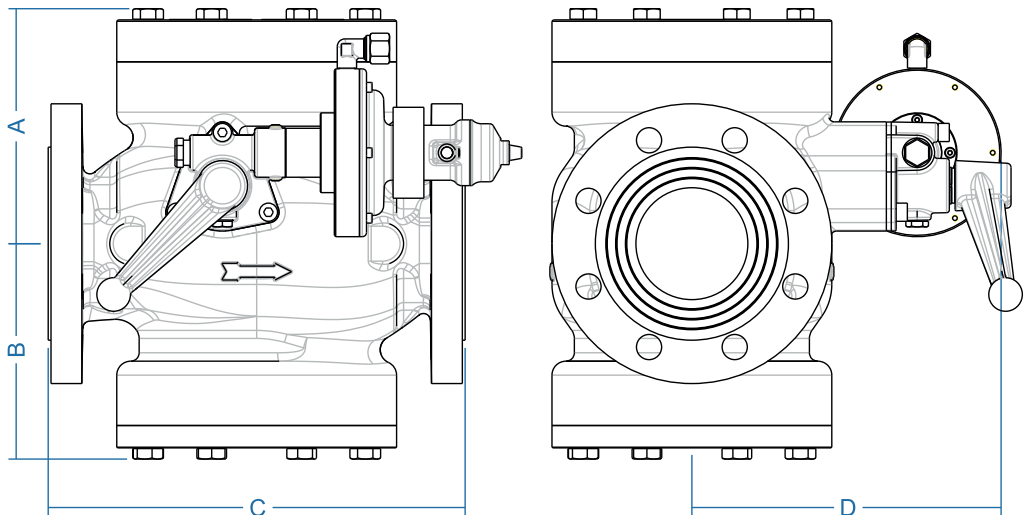

Table 6					
	A	B	C	D	Weight
	inches				lbs
1" NPT	2.36	5.75	3.94	2.68	4.4
1 x 1.5" NPT	2.36	5.75	5.12	2.68	5.5
2" CL125 & CL150	5.32	10.5	10	3.3	40
3" CL300	6.3	6.25	11.75	8.7	120

Figure 9 below indicates the position of the sense line for the 1-2" S26. Please specify desired sense line positions or the standard position (F) will be assumed.

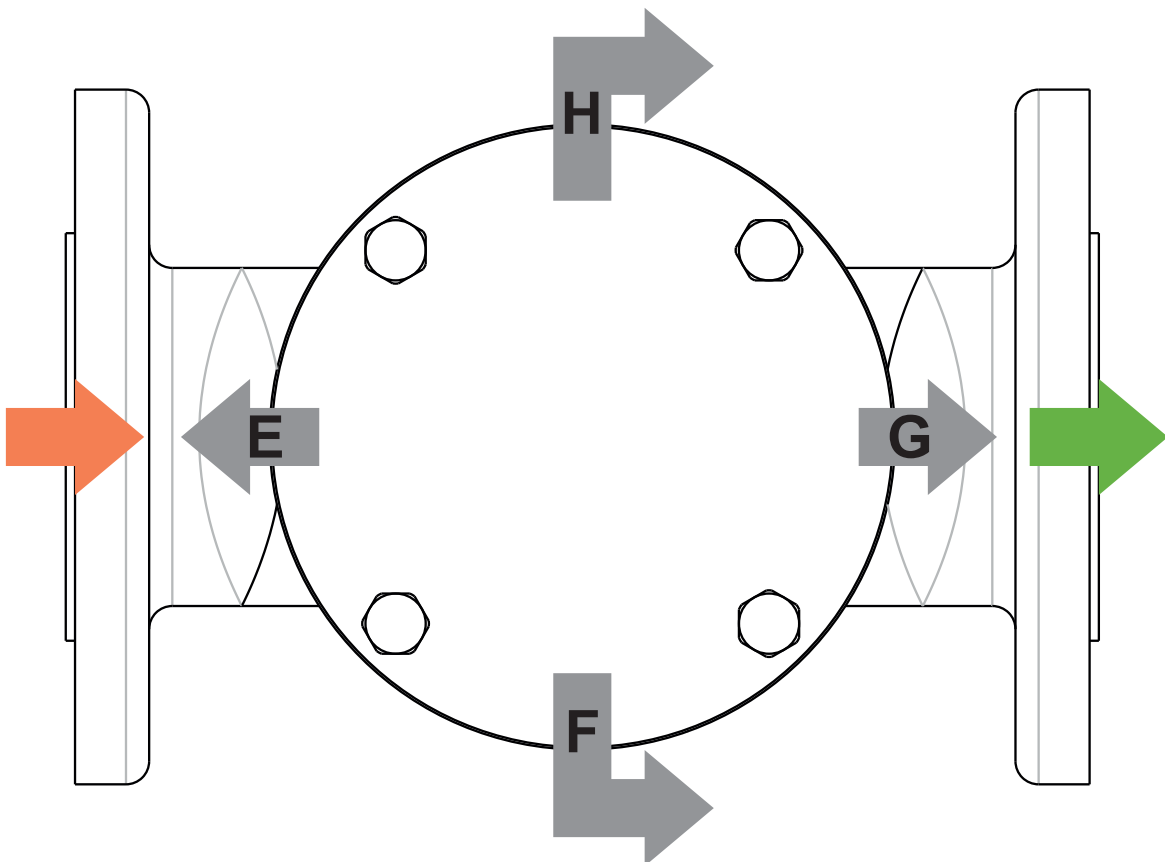

Figure 9: S26 Sense Line Location for 1-2" Constructions.
View is from top, flow is left to right.

9 PRODUCT SELECTION

Choose one option or enter the specific request for each section below. Section 8 above offers common set points, but any set points can be provided upon request.

From Section 7, please specify the product code: S26-VDB_____ - _____ / _____

BODY SIZE

1" NPT -----
 1x1.5" NPT -----
 2" CL125 FF -----
 2" CL150 RF -----
 3" CL150 RF -----

VENT PROTECTOR

*90 Degree Fitting -----
 Standard Umbrella -----
 Inverted Umbrella -----

ACTIVATION POINT

OPSO -----
 UPSO -----

REGULATOR SENSE LINE POSITION

E -----
 *F -----
 G -----
 H -----

* Indicates the standard offering that will be provided unless otherwise specified.

THIS DOCUMENT IS INTENDED FOR REFERENCE ONLY. CAVAGNA GROUP DOES NOT ASSUME RESPONSIBILITY FOR THE SELECTION, USE, OR MAINTENANCE OF ANY PRODUCT. THE PURCHASER IS RESPONSIBLE FOR PROPER SELECTION, USE AND MAINTENANCE OF ANY PRODUCT SPECIFIC TO THE APPLICATION IT IS PURCHASED FOR. THIS DOCUMENT DOES NOT PROVIDE ANY GUARANTEE OR WARRANTY REGARDING THE PRODUCTS HEREIN, NOR DOES IT PROVIDE ANY INSTRUCTIONS OR GUIDELINES RELATING TO THE INSTALLATION, USE, OR MAINTENANCE OF ANY PRODUCTS. WARRANTY TERMS AND GENERAL TERMS AND CONDITIONS OF SALE ARE AVAILABLE AT www.cavagnagroup.com

CAVAGNA GROUP RESERVES THE RIGHT TO MODIFY OR CHANGE THE DESIGN, SPECIFICATIONS, OR FEATURES CONTAINED IN THIS DOCUMENT AND THE PRODUCTS SHOWN HEREIN. CONTACT CAVAGNA GROUP OR YOUR CAVAGNA GROUP DISTRIBUTOR FOR THE LATEST INFORMATION OR FOR A COPY OF THE APPLICABLE USER MANUAL (WHICH MUST BE FULLY READ BEFORE USING THE PRODUCT).



A Cavagna Group Brand

Cavagna North America Inc.

50 Napoleon Court
 Somerset, NJ 08873

info@us.cavagnagroup.com - www.CavagnaNA.com